

L2 SERIES DPDT (TRANSFER) DC - 12.4 GHz

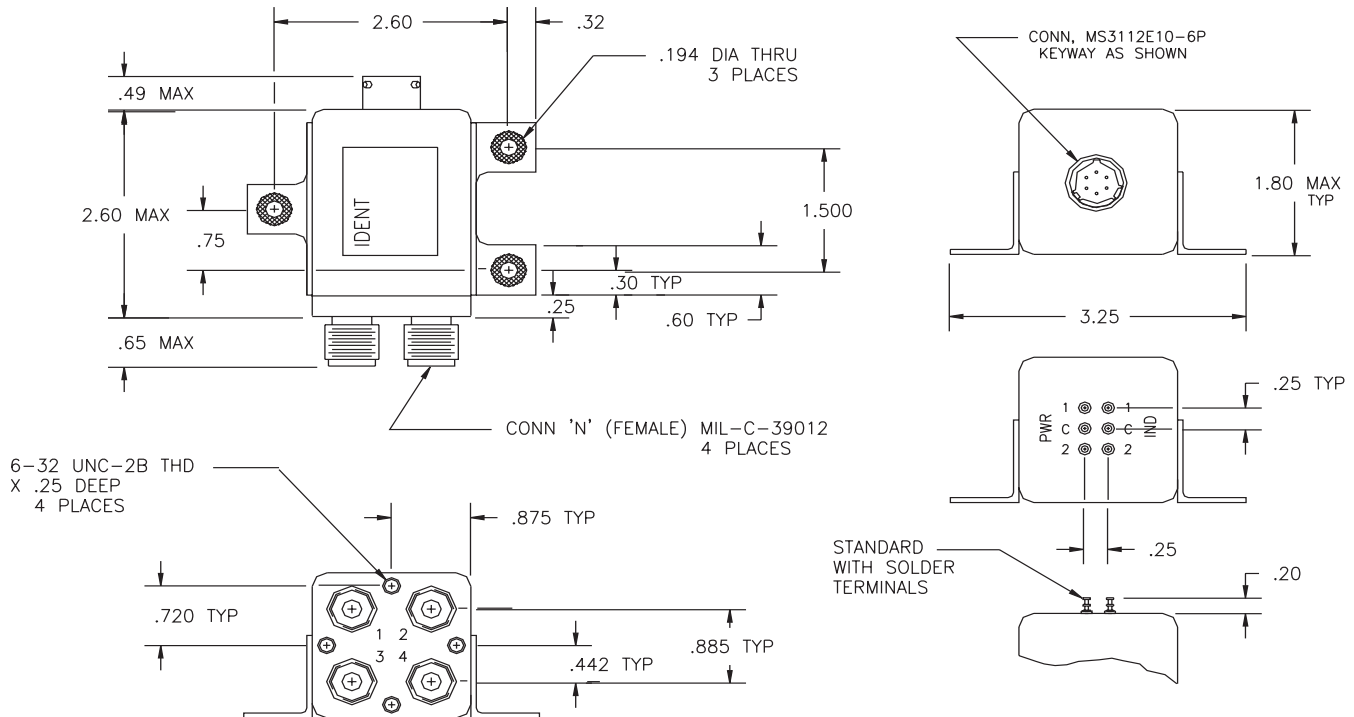

FREQUENCY: GHz	DC - 2.0	2.0 - 4.0	4.0 - 8.0	8.0 - 12.4
VSWR (MAX.)	1.20:1	1.30:1	1.40:1	1.50:1
INSERTION LOSS (MAX.)	0.20	0.30	0.40	0.50
ISOLATION (MIN.)	80	70	70	60
IMPEDANCE	50 Ohms			
MECHANICAL				
CONTACT	:	BREAK BEFORE MAKE		
ACTUATOR	:	FAILSAFE, LATCHING, MOMENTARY		
SWITCHING SPEED	:	20 mSEC MAX.		
ELECTRICAL				
ACTUATOR VOLTAGE	:	28.0, 12.0, 15.0, 24.0 Vdc		
ACTUATOR CURRENT	:	CONTACT CEI		
POWER HANDLING	:	350 WCW @ 1.0 GHz (STANDARD)		
	:	950 WCW @ 1.0 GHz (OPT./P)		
ENVIRONMENTAL				
OPERATING TEMP	:	-40 DEG. C TO 90 DEG. C (STANDARD)		
	:	-54 DEG. C TO 90 DEG. C (OPT./MS)		
SINE VIBRATION	:	30 G'S ms		
RANDOM VIBRATION	:	20 G'S ms		
LIFE	:	1,000,000 CYCLES		
FINISH				
RF CAVITY	:	ALUMINUM ELECTROLESS NICKEL PLATED PER MIL-C-26074, CLASS 4 (EXCEPT LOW OR ULTRA LOW IM MODELS)		
ENCLOSURE	:	ALUMINUM, BLACK OR BLUE		
CONTACT	:	BERYLLIUM COPPER, GOLD PLATED PER MIL-G-45204		
CONNECTOR SHELL	:	CRES, PASSIVATED PER QQ-P-35 OR BRASS, ELECTROLESS NICKEL PLATED PER MIL-C-26074		
AVAILABLE OPTIONS				
INDICATOR CIRCUITRY	:	CUT OFF POWER CIRCUIT		
SUPPRESSION DIODE	:	MS CONNECTOR OR EQUIV. (MIL-SPEC)		
TTL LOGIC	:	D'SUB MINIATURE SERIES		
	:	LOW, ULTRA LOW, AND SUPERIOR INTERMODULATION (IM)		

REFERENCE FOR DIMENSIONS ONLY
AVAILABLE WITH SOLDER TERMINALS, D'SUB OR MS CONNECTOR

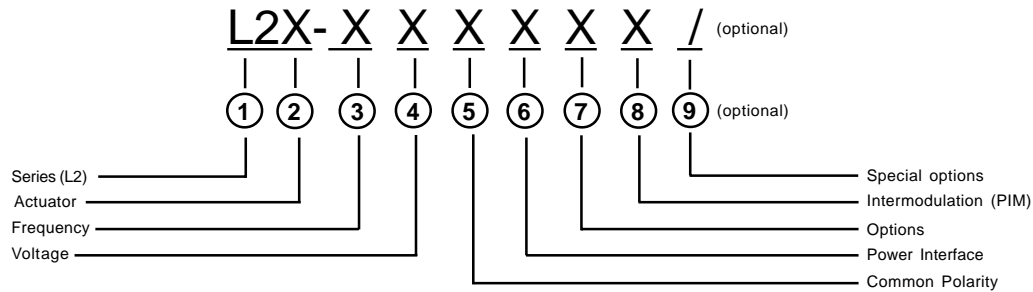

L2 SERIES PART NUMBER & ORDERING INFORMATION

**1 - Switch Series**

L2 DPDT TRANSFER TYPE N

2 - Actuator

F	FAILSAFE	Y	OTHER (SPECIFY)
G	FAILSAFE WITH SUPPRESSION DIODE		
H	FAILSAFE WITH INDICATOR		
J	FAILSAFE WITH SUPPRESSION DIODE AND INDICATOR		
L	LATCHING		
M	LATCHING WITH SUPPRESSION DIODE		
N	LATCHING WITH INDICATOR		
P	LATCHING WITH SUPPRESSION DIODE AND INDICATOR		

3 - Frequency Bandwidth

1	DC - 13.0 GHz
2	DC - 2.0 GHz
3	DC - 12.4 GHz
4	DC - 4.0 GHz
6	DC - 6.0 GHz

4 - Voltage

1	10 - 14 Vdc (12.0 NOMINAL)	4	24 - 32 Vdc (28.0 NOMINAL)
2	13 - 18 Vdc (15.0 NOMINAL)	5	OTHER
3	20 - 30 Vdc (24.0 NOMINAL)	0	NOT REQUIRED

5 - Common Polarity

1	POSITIVE (+) COMMON
2	NEGATIVE (-) OR RETURN V _{dc} COMMON
0	NOT REQUIRED

6 - Power Interface

1	SOLDER TERMINAL (TOP OF SWITCH)	5	D' SUB MINIATURE SERIES (TOP OF SWITCH)
3	CONN MS3112E-XX-XXP OR EQUIV. (TOP OF SWITCH)	8	OTHER

7 - Options

1	CUT OFF POWER CIRCUIT (LATCHING ONLY)	8	OTHER (SPECIFY)
2	TTL LOGIC	9	CUSTOM (ORDER)
3	CUT OFF PWR CIRCUIT & TTL LOGIC (LATCHING ONLY)	0	NO OTHER OPTIONS REQUIRED

8 - Intermodulation

7	LOW PASSIVE INTERMODULATION	9	ULTRA LOW PASSIVE INTERMODULATION
8	SUPERIOR PASSIVE INTERMODULATION	0	STANDARD SWITCH

9 - Special Options (optional - leave blank if not required)

/P	HIGH TEMP, HIGH POWER CONNECTOR
/MS	EXTENDED TEMP RANGE -54 DEG C TO + 90 DEG
/MSP	HIGH TEMP, HIGH POWER CONNECTOR AND EXTENDED TEMP RANGE